

Proportional Directional Control Spool Valve with Position Sensor

PRMF6-10

Size 10 (D05) • Q_{max} 80 l/min (21 GPM) • p_{max} 350 bar (5100 PSI)

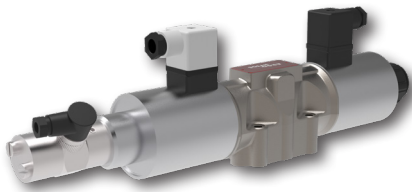

Technical Features

- › Proportional directional control spool valve with subplate mounting surface acc. to ISO 4401 (size 10) and DIN 24340 (CETOP 05)
- › The valve is designed for control of movement direction of actuator and continuous speed regulation in the given range
- › The volumetric flow through the valve is proportional to the electrical input command signal
- › Manual override
- › Spool position sensor with 520h corrosion protection
- › Wide range of electrical connectors
- › Adjustable position of coil connector suitable for mounting
- › In the standard version, the valve housing is phosphated for basic surface corrosion protection and as preparation for painting. Steel parts are zinc-coated for 240 h salt spray protection acc. to ISO 9227
- › Enhanced surface protection for mobile sector available for the valve housing and steel parts (ISO 9227, 520 h salt spray)

Functional Description

The proportional directional control valve is designed to control direction of the movement, speed and position of the piston rod of hydraulic cylinder or shaft of hydraulic motor. The speed of movement is proportional to the volumetric flow through the valve, which is continuously regulated by throttling at the control edges of spool, proportionally to the input command signal. An electronic control unit (ECU) EL7 is used for the valve control. The ECU converts the input command signal into an output current control PWM signal for solenoid coils. The ECU EL7 is available as external for connection to the DIN rail (EL7-E, see datasheet HA 9152) or integrated on the valve in the form of connector plug (EL7-I, see datasheet HA 9151). The valve is equipped with a spool position sensor. However, its output signal is intended for the machine control system and cannot be connected to the valve control loop via ECU EL7.

Technical Data

ISO 4401-05-04-0-05

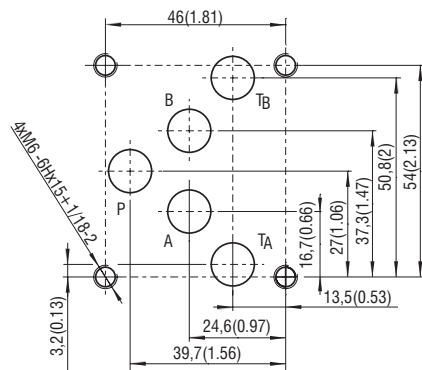

Ports P, A, B a T - max. Ø11.2 mm (0.44 in)

| | | |
|--|-------------------|--------------------------------------|
| Valve size | | 10 (D05) |
| Max. operating pressure at port P, A, B | bar (PSI) | 350 (5080) |
| Max. operating pressure at port T | bar (PSI) | 210 (3050) |
| Fluid temperature range (NBR) | °C (°F) | -30 ... +80 (-22 ... +176) |
| Fluid temperature range (FPM) | °C (°F) | -20 ... +80 (-4 ... +176) |
| Ambient temperature range | °C (°F) | -30 ... +50 (-22 ... +122) |
| Nominal flow rate Q_n at $\Delta p=10$ bar (145 PSI) | l/min (GPM) | 30 (7.9) / 60 (15.9) / 80 (21.13) |
| Hysteresis | % | < 6 |
| Weight - valve with 1 solenoid - valve with 2 solenoids | kg (lbs) | 4.3 (9.48) 5.8 (12.78) |
| Enclosure type acc. to EN 60529 | | IP65 / IP67 (see Dimensions, page 5) |
| Technical data of proportional solenoid | | |
| Nominal supply voltage | V DC | 24 |
| Limit current | A | 1.1 |
| Mean resistance value at 20 °C (68 °F) | Ω | 13.9 |
| Technical data of electronic control unit EL-7 | | |
| Operating supply voltage U_{cc} | V DC | 9 ... 32 |
| Reference voltage U_{ref} | V DC | 5 |
| Max. current at U_{ref} | mA | 20 |
| Types of input command signal, when EL7 is used | | see datasheet EL7* |
| Max. output current / 1 coil | A | 3 |
| PWM frequency | Hz | 80 ... 1 000 |
| Resolution of A/D converters | bit | 12 |
| Ramp function | s | 0 ... 45 |
| Dither – amplitude* | % from I_{max} | 0 ... 30 |
| Dither – frequency* | Hz | 60 ... 300 |
| * When the dither is activated, the PWM frequency is automatically set to 15 kHz | | |
| | Datasheet | Type |
| General information | HA 0060 | products and operating conditions |
| Coil types / Connectors | HA 8007 / HA 8008 | C31* / K* |
| Mounting interface | HA 0019 | Size 10 |
| Spare parts | HA 8010 | |
| Subplates | HA 0002 | DP*-10 |

Ordering Code

PRMF6-10 [] / [] - [] [] [] [] [] [] [] - []

Proportional directional control spool valve with position sensor

Valve size

Spool symbols see table „Spool Symbols“

| Nominal flow rate at Δp=10 bar (145 PSI) | |
|--|----|
| 30 l/min (7.9 GPM) | 30 |
| 60 l/min (15.85 GPM) | 60 |
| 80 l/min (21 GPM) | 80 |

Rated supply voltage of solenoid (at the coil terminal) 24 V DC 24

Integrated electronic control unit (standardly on the solenoid „a“)

Electronic control unit EL7-IA with an analogue input command signal EL7-A
Electronic control unit EL7-IC for connection to the CAN bus EL7-C

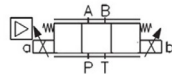

Surface treatment
No designation standard
B zinc-coated (ZnNi), ISO 9227 (520 h)

Seals
No designation NBR
V FPM (Viton)

Connector plug of position sensor
No designation without connector plug
KM connector plug M12x1 (4 pins)

Spool position sensor (always on the solenoid „a“)
S01 sensor with analogue output 0 - 5 V DC
S02 sensor with analogue output 4 - 20 mA
S04 sensor with analogue output 12 - 3 V DC
S06 sensor with analogue output 0 - 10 V DC

Manual override
No designation standard (operated by pin)
N1 cap nut covered
N2 rubber boot protected

Connector plug acc. to EN 175301-803-A valve with integrated electronic control unit
K1 connector plug EN 175301-803-A without rectifier for the valve without integrated ECU and with coils E1 or E2

Connector (only for valves without EL7-I)
EN 175301-803-A
E1 with quenching diode
E2 AMP Junior Timer - radial direction (2 pins; male)
E3 with quenching diode
E4
E12A Deutsch DT04-2P - axial direction (2 pins; male)
E13A E12A with quenching diode

- For proportional valves with two solenoids, one solenoid must be de-energized before the other solenoid can be charged.
- Mounting bolts M6 x 45 DIN 912-10.9 or studs must be ordered separately. Tightening torque is 14+1 Nm (10.3+0.7 lbf.ft).
- Besides the shown, commonly used valve versions other special models are available.
- Contact our technical support for their identification, feasibility and operating limits.

Spool Symbols

| Typ | Symbol | Typ | Symbol | Typ | Symbol |
|------|--------|------|--------|------|--------|
| 2Z51 | | 3Z11 | | 3Z21 | |
| 2Z11 | | 3Z12 | | 3Y21 | |
| 2Y51 | | 3Y11 | | | |
| 2Y11 | | 3Y12 | | | |

*Model for cylinders with asymmetric piston area ratio

Characteristics measured at $v = 32 \text{ mm}^2/\text{s}$ (156 SUS)

Operating limits: Flow direction $P \rightarrow A / B \rightarrow T$ or $P \rightarrow B / A \rightarrow T$

Nominal flow 30 l/min (7.95 GPM)

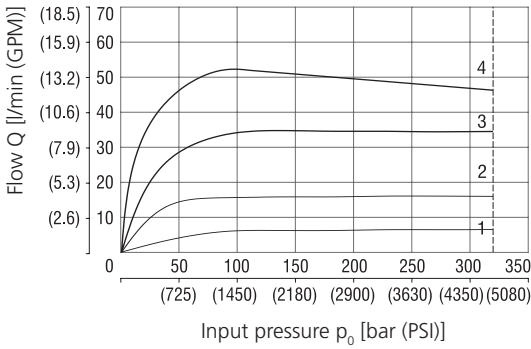

Nominal flow 60 l/min (15.85 GPM)

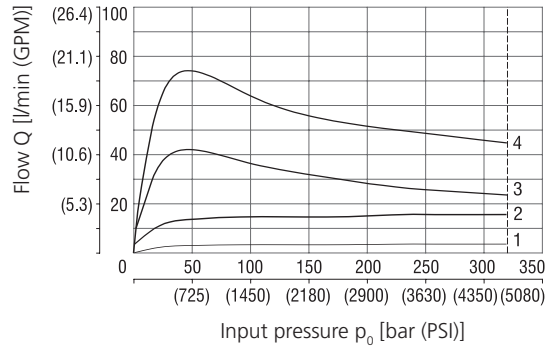

Solenoid current:

- 1 = 40 %
- 2 = 60 %
- 3 = 80 %
- 4 = 100 %

Nominal flow 80 l/min (21.13 GPM)

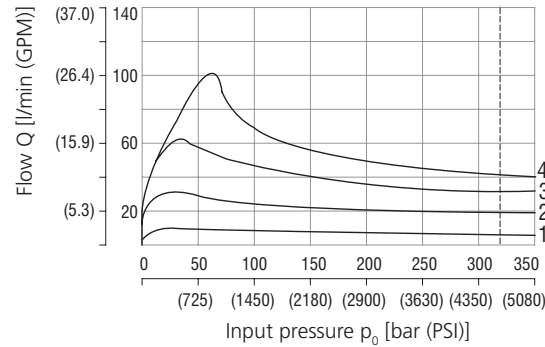

Regulated flow related to control signal

$\Delta p = 10 \text{ bar}$ (145 PSI)

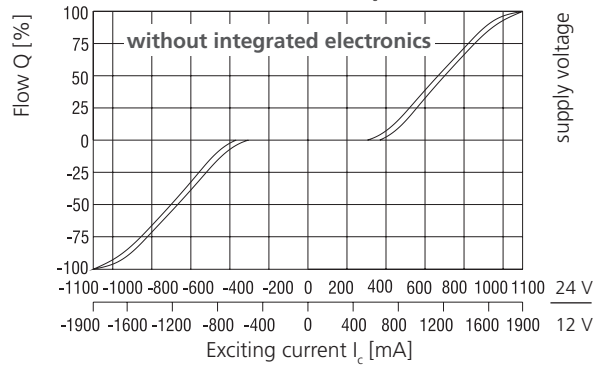
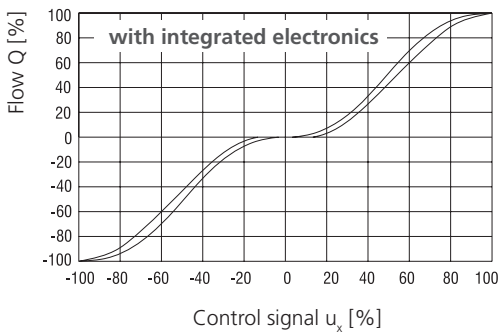

supply voltage

The coil current which initializes the flow through the proportional directional valve can differ due to the production tolerances about in a range of $\pm 6\%$ of the limit current.

Transient Characteristic measured at $v = 32 \text{ mm}^2/\text{s}$ (156 SUS), $\Delta p = 10 \text{ bar}$ (145 PSI)

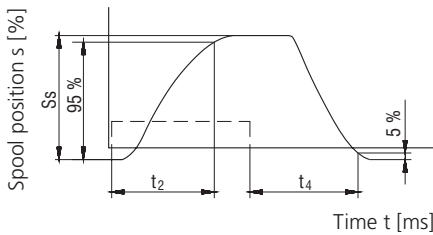

| Steady Spool Position S_s [%] | t_2 [ms] | t_4 [ms] |
|---------------------------------|------------|------------|
| 100 | 85 | 100 |
| 75 | 70 | 85 |
| 50 | 55 | 75 |
| 25 | 45 | 55 |

The values in table have only an informative character. The times of the transient characteristics at pressure or flow control will be in a particular hydraulic circuit always longer.

---- the control signal course of the integrated electronics

Frequency Response

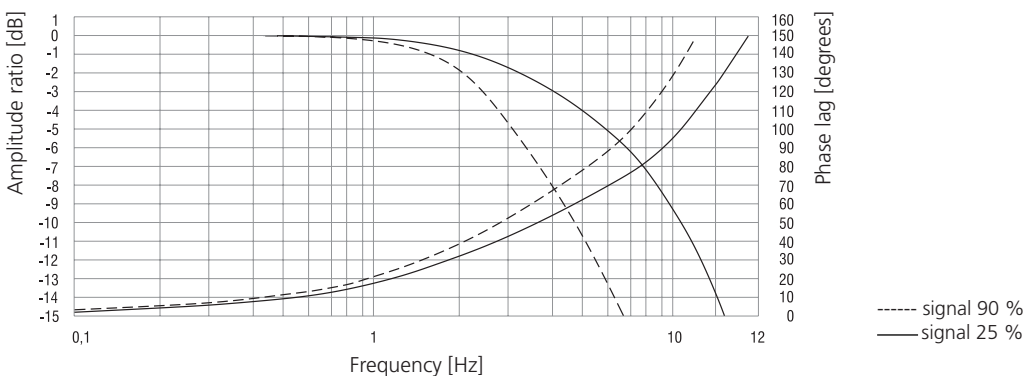

Electronic control unit EL7

The ECU EL7 allows direct independent control of the valve with an analogue input command signal or connection of the valve to the CANBus control system of machine.

Proportional valve with external electronic control unit EL7-E

The valve can be controlled by external ECU EL7-E designed for connection to a DIN rail. The user electrically connects the ECU to the valve with a cable. The ECU EL7-E can be used for control of one solenoid or two solenoid valves.

Selection and setting of ECU parameters is described in **datasheet HA 9152**

Valve with one solenoid and integrated ECU EL7-I*-1

The ECU in the form of connector plug is simply mounted on the socket of connector EN 175301-803-A of solenoid coil and fastened with a fixing screw.

Valve with two solenoids and integrated ECU EL7-I*-2-105

The ECU in the form of connector plug is simply mounted on the socket of connector EN 175301-803-A of solenoid coil and fastened with a fixing screw. The second solenoid is connected to the ECU with a cable. If the integrated ECU EL7-I is ordered separately, the length of cable must be specified. The length of cable is defined as a distance between fastening screws of ECU and connector plug.

Selection and setting of ECU parameters is described in **datasheet HA 9151**

Spool position sensor

The spool position sensor is designed to monitoring of actual spool position by control system of machine. The proportional valve can thus operate in a closed control loop with feedback. The sensor works on the principle of differential transformer (LVDT). The sensor core is firmly mechanically connected with a rod to the solenoid armature, which is pressed by spring force to the face of spool inside the valve body. The ECU EL7 does not have any port for connection of sensor as a feedback and allows the valve control only in the open loop. A circular 4-pin M12x1 connector is used for an electrical connection. The surface of sensor is blue chromated.

Technical Data

| | | |
|----------------------------------|----------------------------|------------------------------|
| Max. fluid pressure | bar (PSI) | 350 (5080) |
| Supply voltage | V DC | 24 (±10 %) |
| Power current consumption | mA | > 20 (no load) |
| Linearity | % from the measuring range | < ±1 |
| Repeatability | % from the measuring range | 0.1 |
| Temperature drift | % from the measuring range | < ±0.05 |
| Current output signal | mA | 4 ...20 |
| Voltage output signal | V DC | 0 ... 5 / 0 ...10 / 12 ... 3 |
| Load resistance – current output | Ω | < 500 |
| Load resistance – voltage output | kΩ | > 10 |
| Limit frequency | kHz | 1 |
| Stroke range of sensor core | mm (in) | ±4 (0.158) |
| Weight with connector plug | kg (lbs) | 0.240 (0.53) |
| Operating temperature range | °C (°F) | -40 ... +85 (-40 ... +185) |
| Storage temperature range | °C (°F) | -40 ... +85 (-40 ... +185) |
| Electrical enclosure protection | | IP65 * |
| Resistance to mechanical shocks | | 200 g, 2ms |
| Resistance to vibrations | | 10 g / 2 Hz ... 2 kHz |

* under the condition of correctly mounted connector plug

Electrical connection of sensor

| | | |
|-------|---------------------------------------|---|
| Pin 1 | Supply voltage 24 ($\pm 10\%$) V DC |  |
| Pin 2 | Output signal | |
| Pin 3 | GND | |
| Pin 4 | Unconnected | |

Dimensions of position sensor in millimeters (inches)

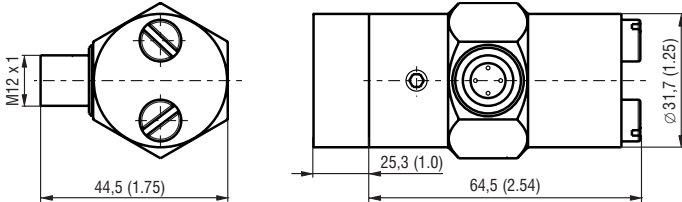

Solenoid Coil in millimeters (inches)

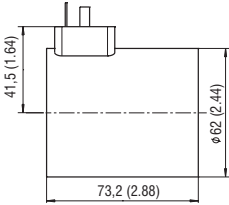
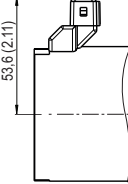
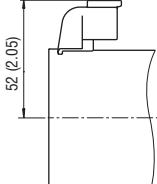
| E1, E2 Protection Degree IP65 | E3, E4 Protection Degree IP65 / IP67 | E12A, E13A Protection Degree IP67 / 69K |
|--|--|--|
|  |  |  |

The specified IP rating applies only in the case of correctly connected connectors (male + female) with the corresponding IP rating.

Manual Override in millimeters (inches)

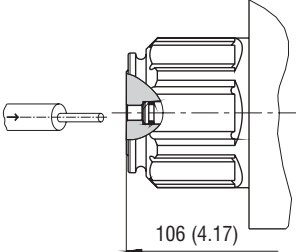
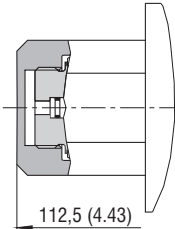
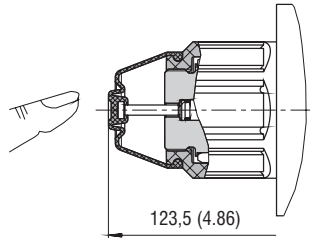
| No Designation - Standard (operated by pin) | Designation N1 - Cap Nut Covered | Designation N2 - Rubber Boot Protected |
|---|---|---|
|  |  |  |

In case of solenoid malfunction or power failure, the spool of the valve can be shifted by manual override as long as the pressure in port T does not exceed 25 bar (363 PSI). For alternative manual overrides contact our technical support.

Dimensions in millimeters (inches)

PRMF6-103..../...-....EL7...S0...

Valve with two solenoids and position sensor

Example with electrical terminal
EN 175301-803-A (E1, E2)

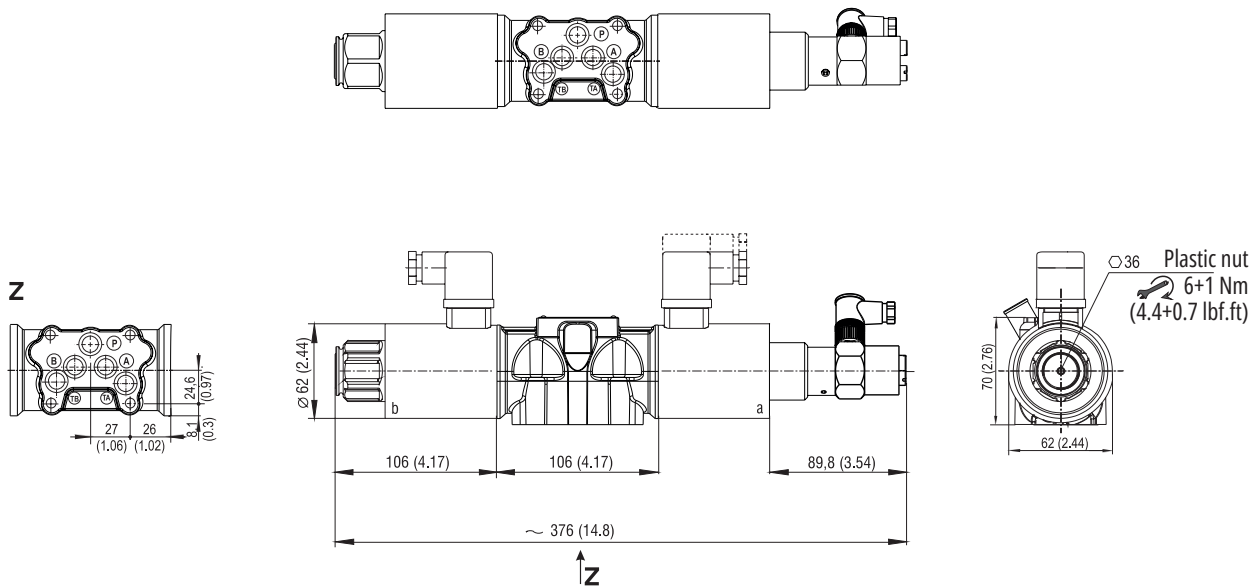

PRMF6-102..../...-....E1K1...S...KM...

Valve with one solenoid „b” and position sensor

Spool type 2Z11, 2Y11

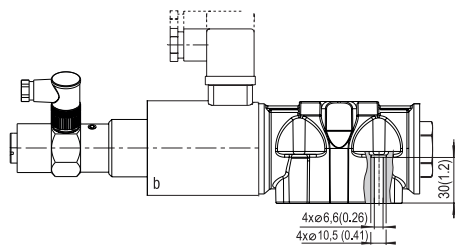

PRMF6-102..../...-....E1K1...S...KM...

Valve with one solenoid „a” and position sensor

Spool type 2Z51, 2Y51

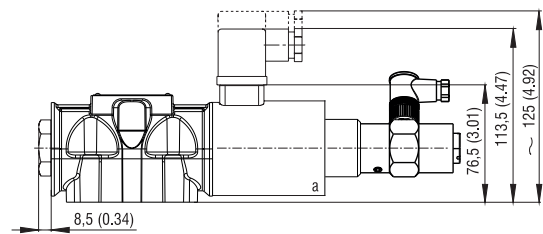

PRMF6-102..../...-....EL7...S0...

Valve with one solenoid „a”, integrated electronic control unit EL-I*-1 and position sensor

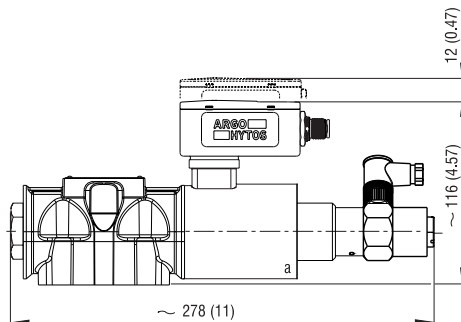

PRMF6-103..../...-....EL7...S0...

Valve with two solenoids, integrated electronic control unit EL-I*-2-105 and position sensor

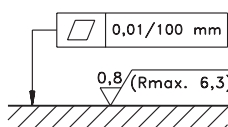
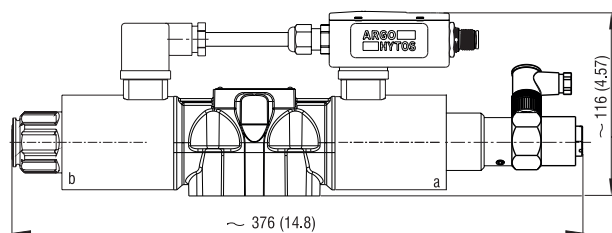

Required surface quality of the counterpart

Mounting screws 14+1 Nm (10.3+0.7 lbf.ft)
M6 x 45 DIN 912-10.9